



Product Documentation

Gear Pump Series 2030 - 5030

Magnetically Coupled Gear Pumps

The Gear Pump Series 2030, 3030, 4030, and 5030 are an optimization of the existing series 3000 and 8200.

These pumps can cover dosing ranges of 20 ml/min up to 60 l/min.

With a magnetically coupled sealless design, this series of pumps allows for the effective transfer of aggressive and hazardous fluids as well as other non-lubricating fluids.

Typical application areas are the transfer of acids and bases, the feed and discharge out of vaporizers and the circulation of flush fluids in rotating mechanical seal systems.



Flow Rate At Atmospheric Pressure

Pump size	(cc/rev)	Rotation speed (RPM)							
		690	830	950	1150	1450	1725	2830	3360
2030-009	0.09	0.062	0.075	0.086	0.104	0.131	0.155	0.255	0.302
2030-015	0.16	0.110	0.133	0.152	0.184	0.232	0.276	0.453	0.538
2030-027	0.26	0.179	0.216	0.247	0.299	0.377	0.449	0.736	0.874
3030-045	0.45	0.31	0.37	0.43	0.52	0.65	0.78	1.27	1.51
3030-070	0.7	0.48	0.58	0.67	0.81	1.02	1.21	1.98	2.35
3030-110	1.1	0.76	0.91	1.05	1.27	1.60	1.90	3.11	3.70
4030-280	2.8	1.93	2.32	2.66	3.2	4.1	4.8	7.9	9.4
4030-450	4.5	3.11	3.74	4.28	5.2	6.5	7.8	12.7	
4030-710	7.1	4.90	5.89	6.75	8.2	10.3	12.2	20.1	
5030-130	13	9.0	10.8	12.4	15.0	18.9	22.4	36.8	
5030-210	21	14.5	17.4	20.0	24.2	30.5	36.2		
5030-350	35	24.2	29.1	33.3	40.3	50.8	60.4		

Application Area

	Standard Program	Custom Applications
Temperature Range	-20°C to 130°C	-40°C to 250°C
Differential Pressure	10bar (16bar for customized designs)	50 bar
Inlet Pressure	-0.1 to 100 bar	-0.02 to 250 bar
Viscosity Range	0.5 to 3,000mPas	0.3 to 50,000 mPas

Magnetically Coupled Gear Pump Series 2030 - 5030

Application in Ex-Areas

Depending on the design of the drive according to ATEX (94/9/EG) the pumps can be applied in the following zones:

- Zone 1 II 2G
- Zone 21 II 2D
- Zone 2 II 3G
- Zone 22 II 3D

The temperature class depends highly on the temperature of the transferred fluid. The temperature class cannot be rated across the board but has to be individually defined according to the design of the system. Possible temperature classes of basic types are:

- T4 135°C
- T5 100°C
- T6 85°C

For specific adaptations the following temperature classes are also possible:

- T2 300°C
- T3 200°C

Drives / Motors

Pumps can be furnished with or without standard Electric Motor Drives. Please consult a Scherzinger Representative for any non-standard drive request to insure proper technical design coordination.

Pumps are designed for adapter mounting to the following standard IEC Metric Frame 3-Phase Drives:

Pump size	IEC Motor Frame Size						
	56	63	71	80	90	100	112
2030-009	x		x				
2030-015	x		x				
2030-027	x		x				
3030-045		x	x				
3030-070		x	x				
3030-110		x	x				
4030-280			x	x			
4030-450			x	x			
4030-710			x	x			
5030-130				x	x	x	x
5030-210				x	x	x	x
5030-350				x	x	x	x

The following non-standard drives options are available upon request:

- DC Brushless Motors
- EC Direct Current Drives
- Gear Motors
- Special Baseplate Designs

Design

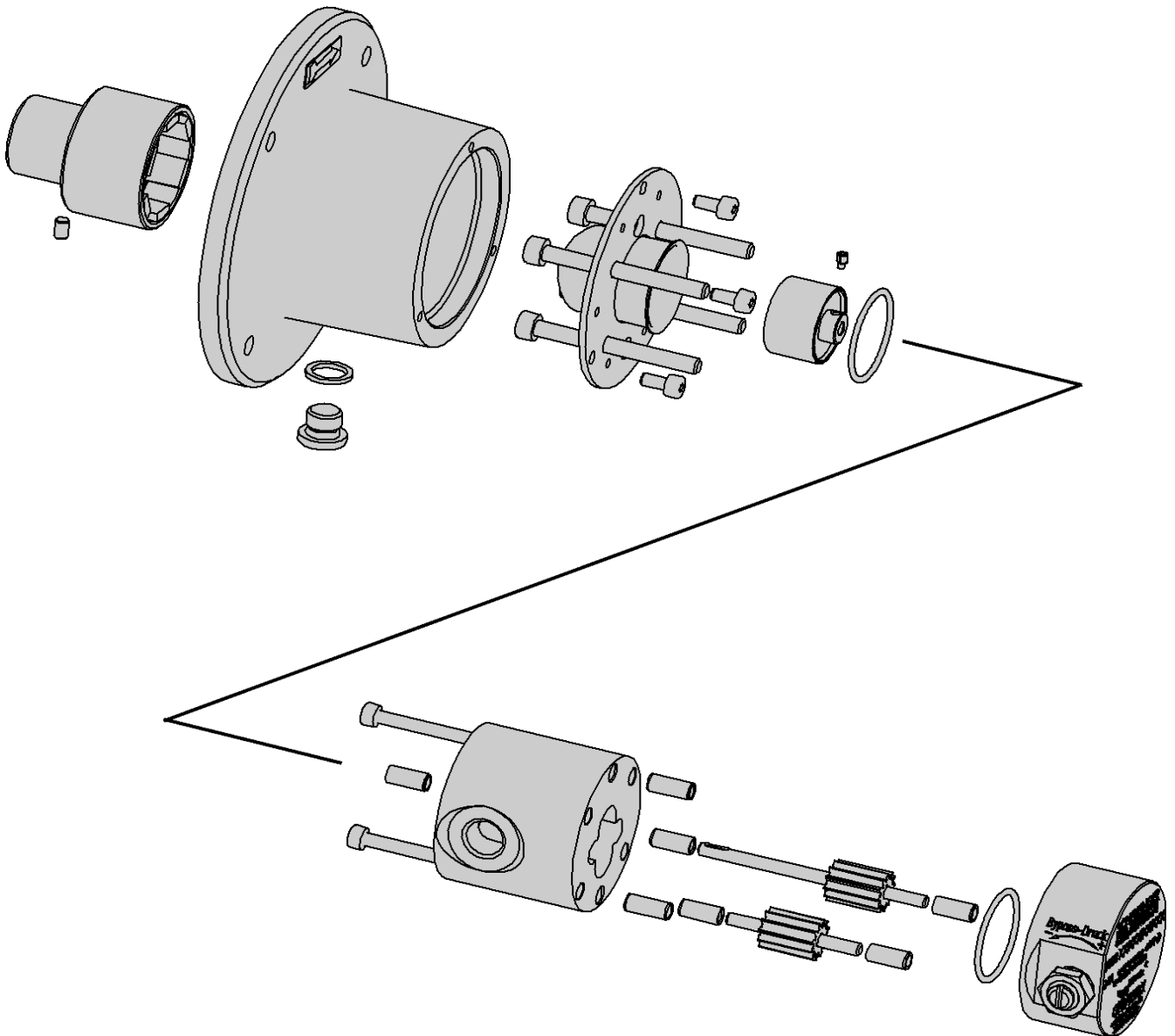

In order to ensure leak-free operation, our pumps are simultaneously sealed and driven over a magnetic coupling. The pumps are statically sealed using O-Rings, eliminating the need for a rotary shaft seal. The drive magnet assembly is mounted on the shaft of the motor. The magnet transmits the torque over the non-magnetic containment shell through to the driven magnet assembly. The driven magnet assembly is mounted on the drive shaft within the interior of the pump.

The pump body is comprised of two housing components. The shafts with fixed gears are assembled in the cover and housing, supported by sleeve type bearings. The gears are optimized to reduce noise and pulsation during operation.

Magnetically Coupled Gear Pump Series 2030

Dimensions

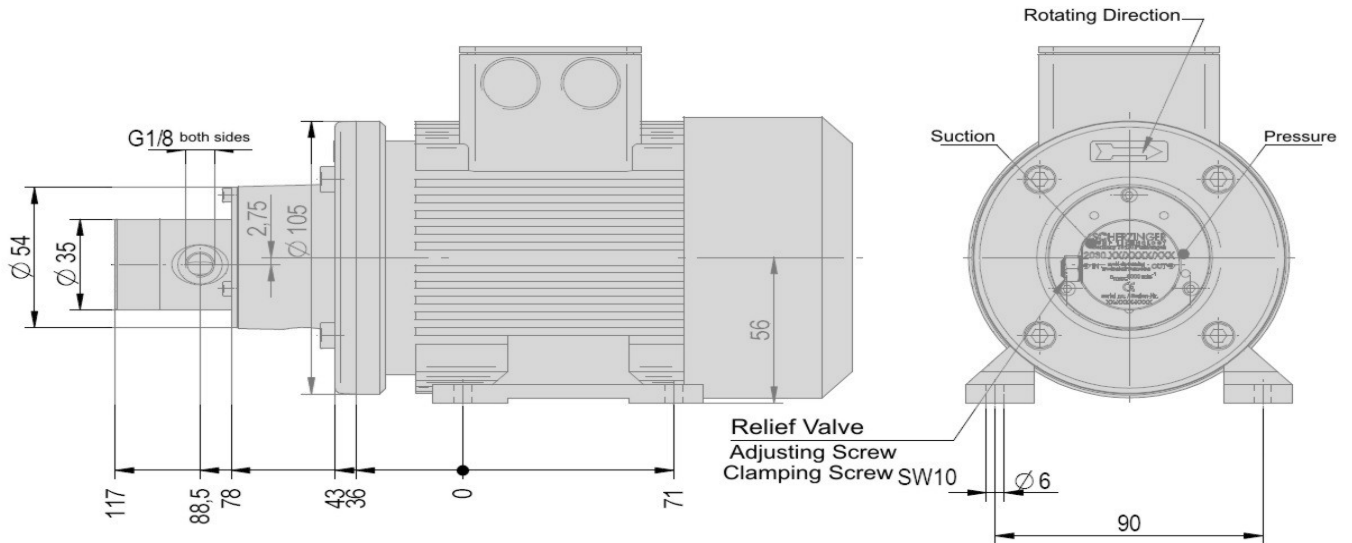

Typical dimensions of pump type 2030-016-B-DM06-2

Pump Specification

	2030-009	2030-016	2030-026
Displacement	0.09 ml/rev	0.16 ml/rev	0.26 ml/rev
Max. Rotation Speed	6,000 RPM	6,000 RPM	6,000 RPM
Max. Discharge 1450 1/min	130 ml/min	210 ml/min	390 ml/min
Max. Discharge 2830 1/min	250 ml/min	420 ml/min	760 l/min
Max. Discharge 6000 1/min	540 ml/min	900 ml/min	1620 l/min
Max. Differential Pressure	10 bar	10 bar	10 bar
Max. Inlet Pressure	100 bar	100 bar	100 bar
Max. Suction Negative Pressure Absolute	150 mbar	150 mbar	150 mbar
Temperature Range PEEK	-20 to 130°C	-20 to 130°C	-20 to 130°C
Temperature Range PTFE	-20 to 70°C	-20 to 70°C	-20 to 70°C
Viscosity Range	0.5 to 3,000mPas	0.5 to 3,000mPas	0.5 to 3,000mPas
Direction of Rotation	optional	optional	optional
Connections	G 1/8"	G 1/8"	G 1/8"
By-Pass Relief Valve	Not Available	Not Available	Not Available
Max. Transmitted Torque of the Mag Drive	250 mNm	250 mNm	250 mNm

**Material Standard Program 2030
and extended Standard Program 2040 & 2050**

	Stainless Steel 2030	Hastelloy 2040	Titanium 2050
Case	1.4571	Hastelloy C4	Titanium Grade 7
Shafts	1.4571	Hastelloy C4	Titanium Grade 7
Gears	PEEK mod.	PTFE mod.	PTFE mod.
Magnets	Ferrite	Ferrite	Ferrite

Customized designs and adaptations are possible after coordination with our engineering team.

Magnetically Coupled Gear Pump Size 2030-009

Pump Head 2030-009
measured with water 1mPas

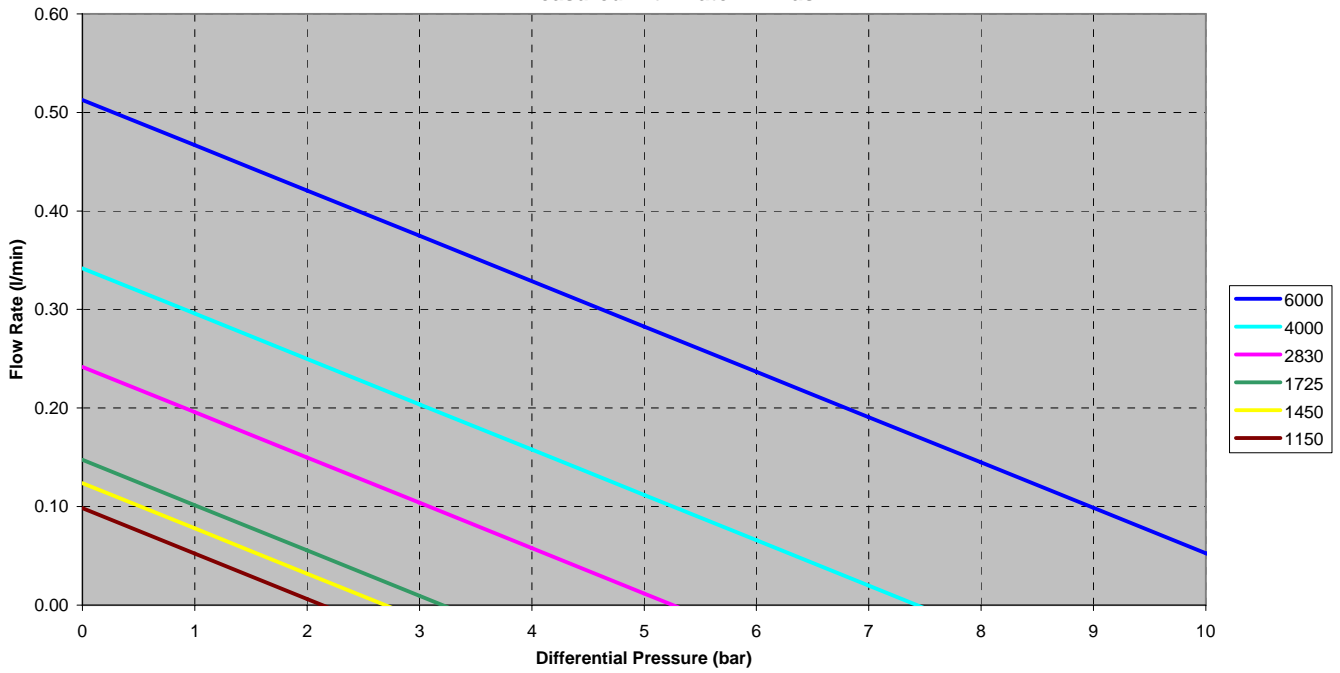

Pump Head 2030-009
measured with oil 100mPas

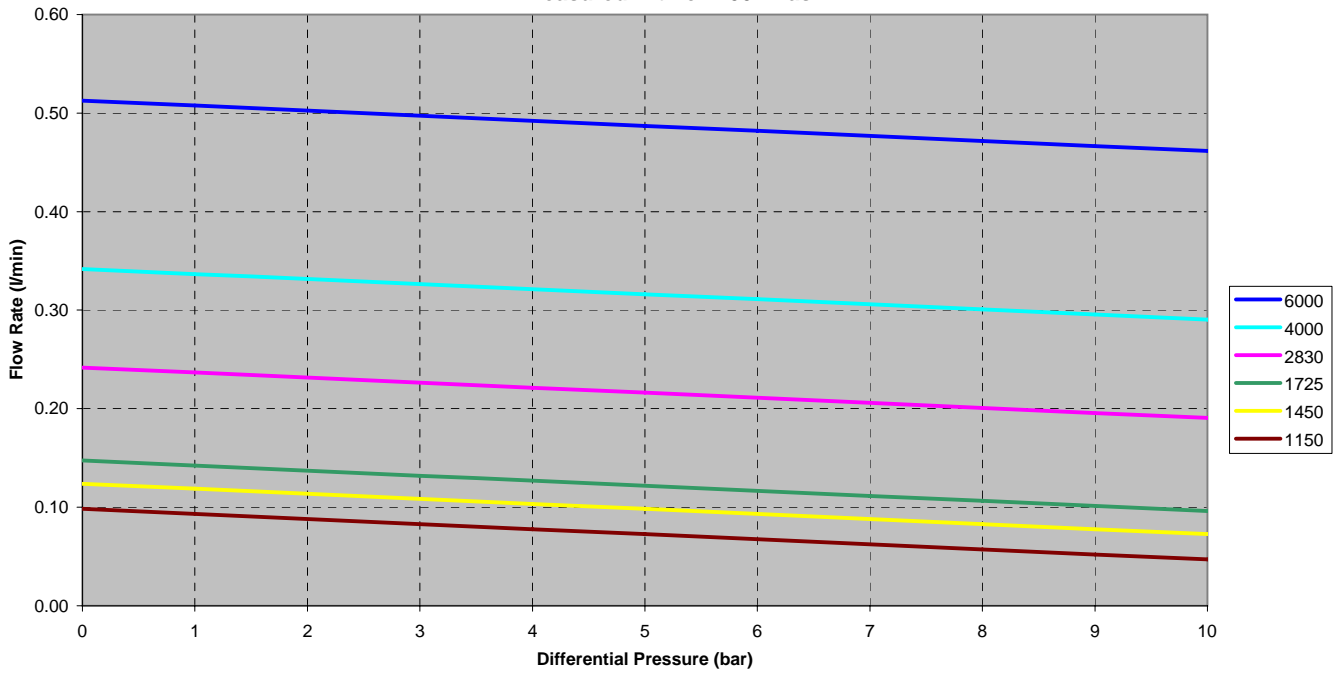

Magnetically Coupled Gear Pump Size 2030-016

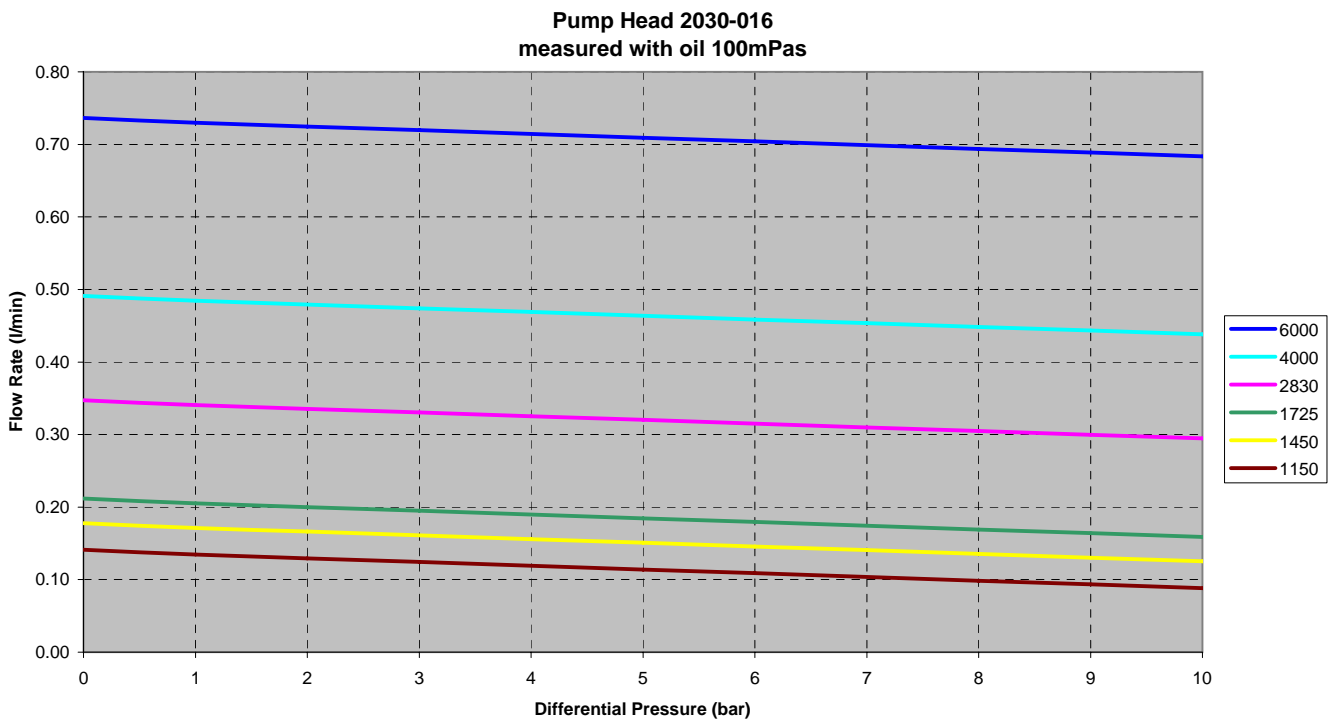
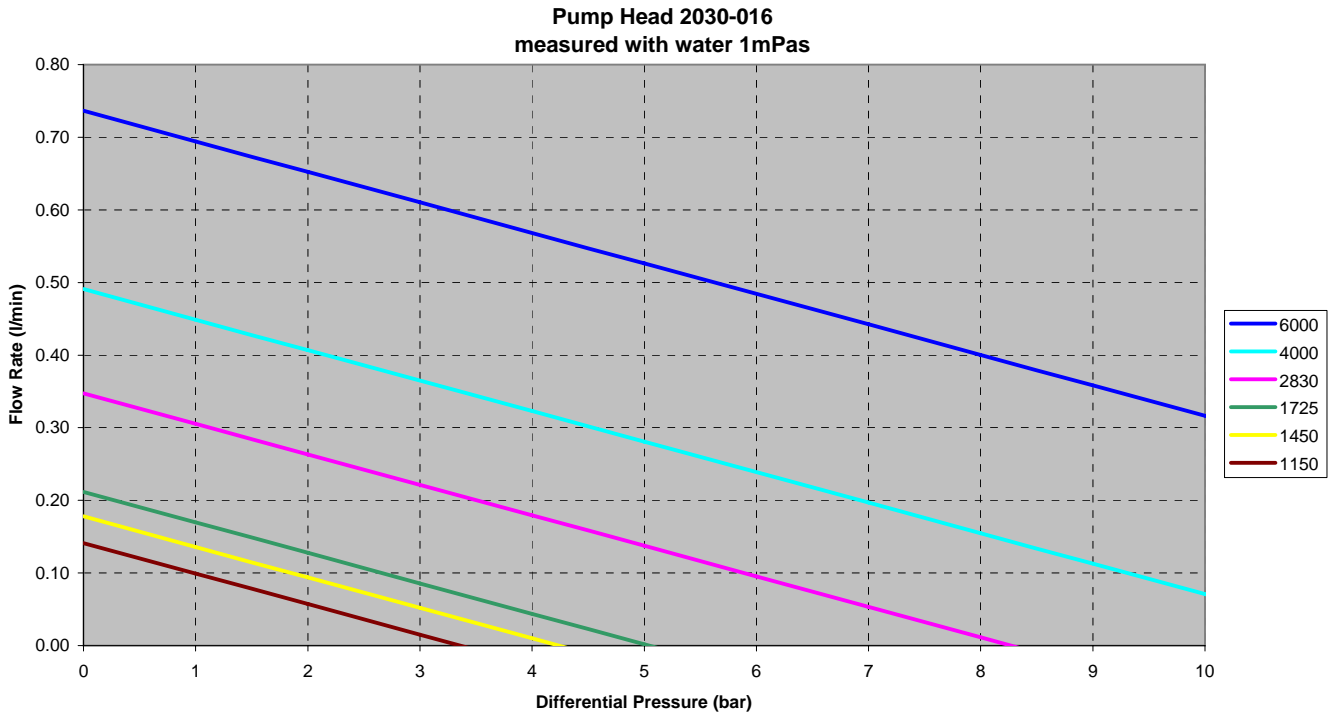

Magnetically Coupled Gear Pump Size 2030-026

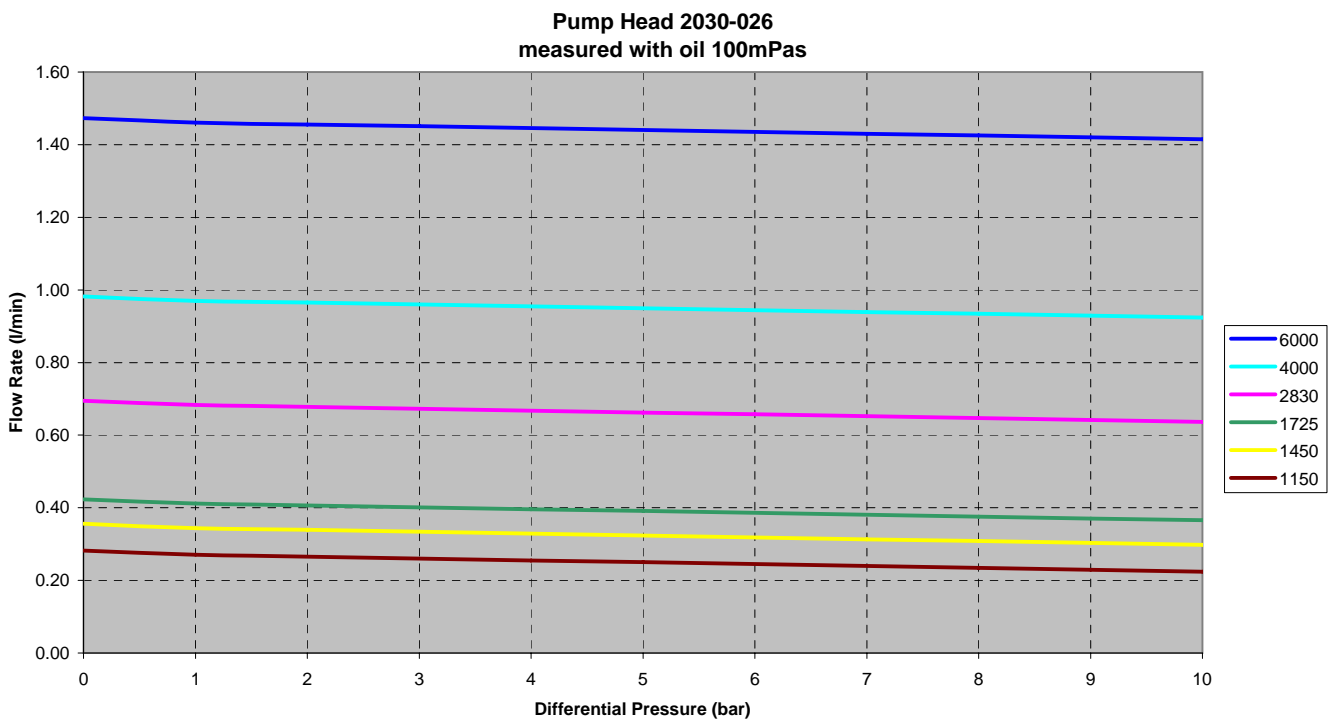
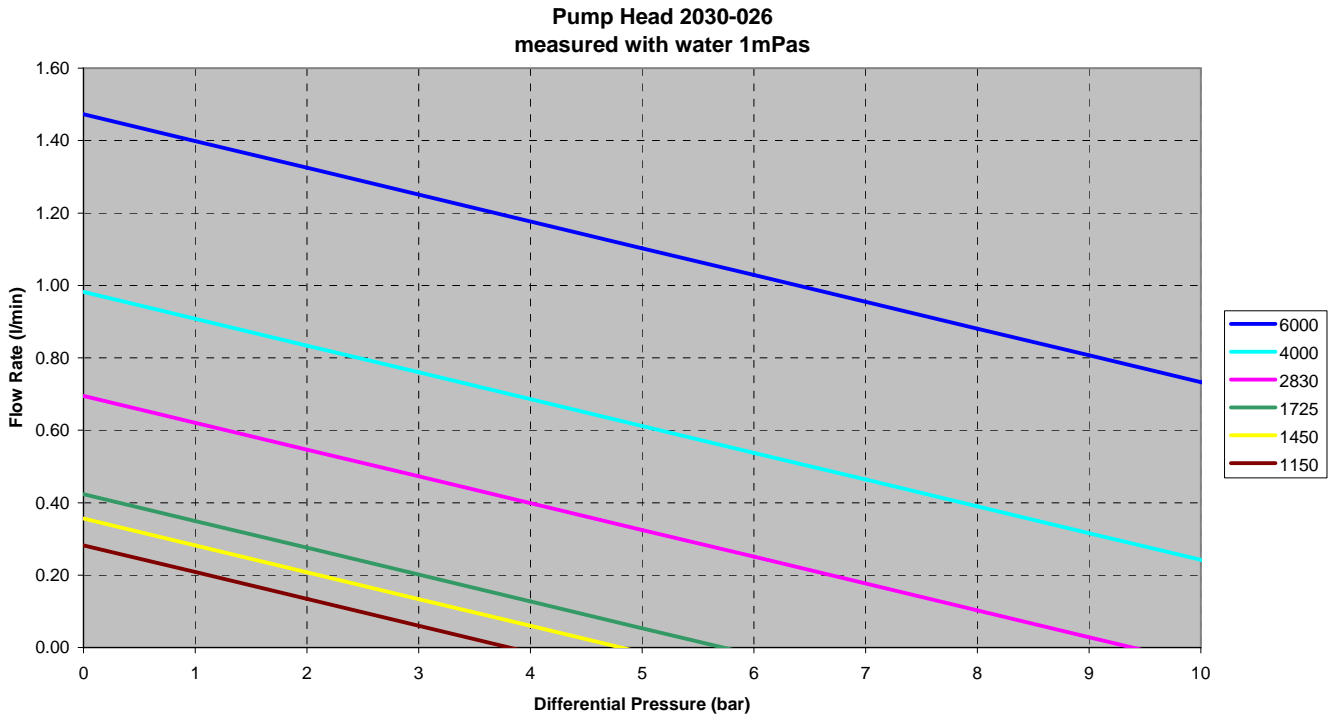

Magnetically Coupled Gear Pump Series 3030

Dimensions

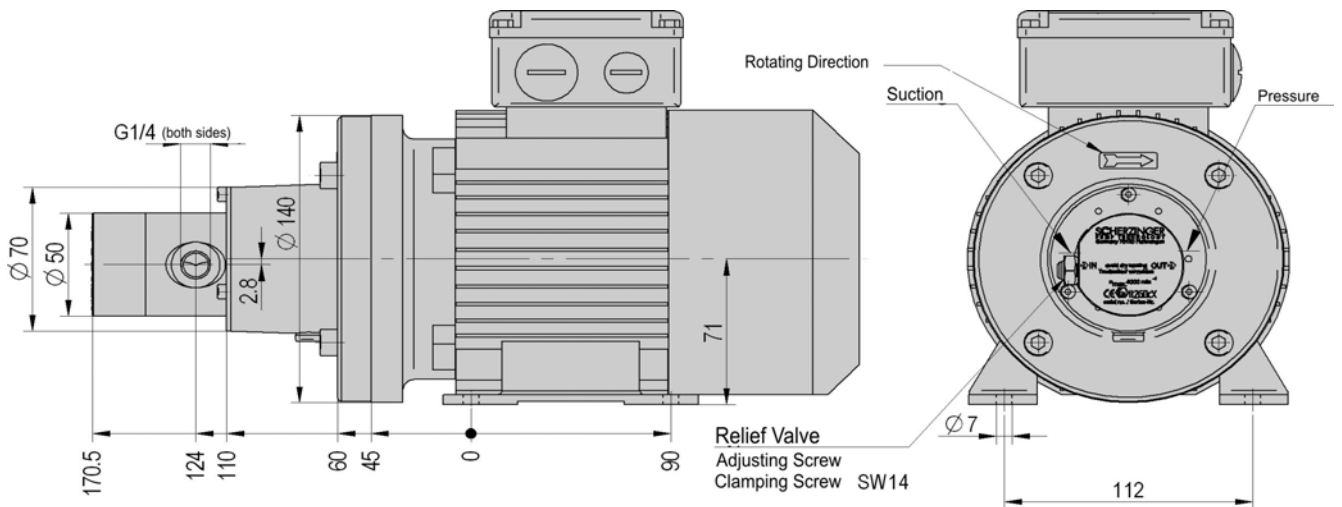

Typical dimensions of pump type 3030-070-B-DM37-4

Pump Specifications

	3030-045	3030-070	3030-110
Displacement	0.45 ml/rev	0.7 ml/rev	1.10 ml/rev
Max. Rotation Speed	4,000 RPM	4,000 RPM	4,000 RPM
Max. Discharge 1450 1/min	0.65 l/min	1.05 l/min	1.59 l/min
Max. Discharge 2830 1/min	1.27 l/min	1.98 l/min	3.11 l/min
Max. Discharge 4000 1/min	1.8 l/min	2.8 l/min	4.4 l/min
Max. Differential Pressure	12 bar	12 bar	12 bar
Max. Inlet Pressure	100 bar	100 bar	100 bar
Max. Suction Negative Pressure Absolute	100 mbar	100 mbar	100 mbar
Temperature Range PEEK	-20 to 130°C	-20 to 130°C	-20 to 130°C
Temperature Range PTFE	-20 to 70°C	-20 to 70°C	-20 to 70°C
Viscosity Range	0.5 to 3,000mPas	0.5 to 3,000mPas	0.5 to 3,000mPas
Direction of Rotation	optional	optional	optional
Connections	G 1/4"	G 1/4"	G 1/4"
By-Pass Relief Valve	optional	optional	optional
Max. Transmitted Torque of the Mag Drive	600mNm	600mNm	600mNm

Material Standard Program 3030 and extended Standard Program 3040 & 3050

	Stainless Steel 2030	Hastelloy 2040	Titanium 2050
Case	1.4571	Hastelloy C4	Titanium Grade 7
Shafts	1.4571	Hastelloy C4	Titanium Grade 7
Gear	PEEK mod.	PTFE mod.	PTFE mod.
Magnets	SmCo	SmCo	SmCo

Customized designs and adaptations are possible after coordination with our engineering team.

Magnetically Coupled Gear Pumps Size 3030-045

**Pump Heads 3030-45
measured with water 1mPas**

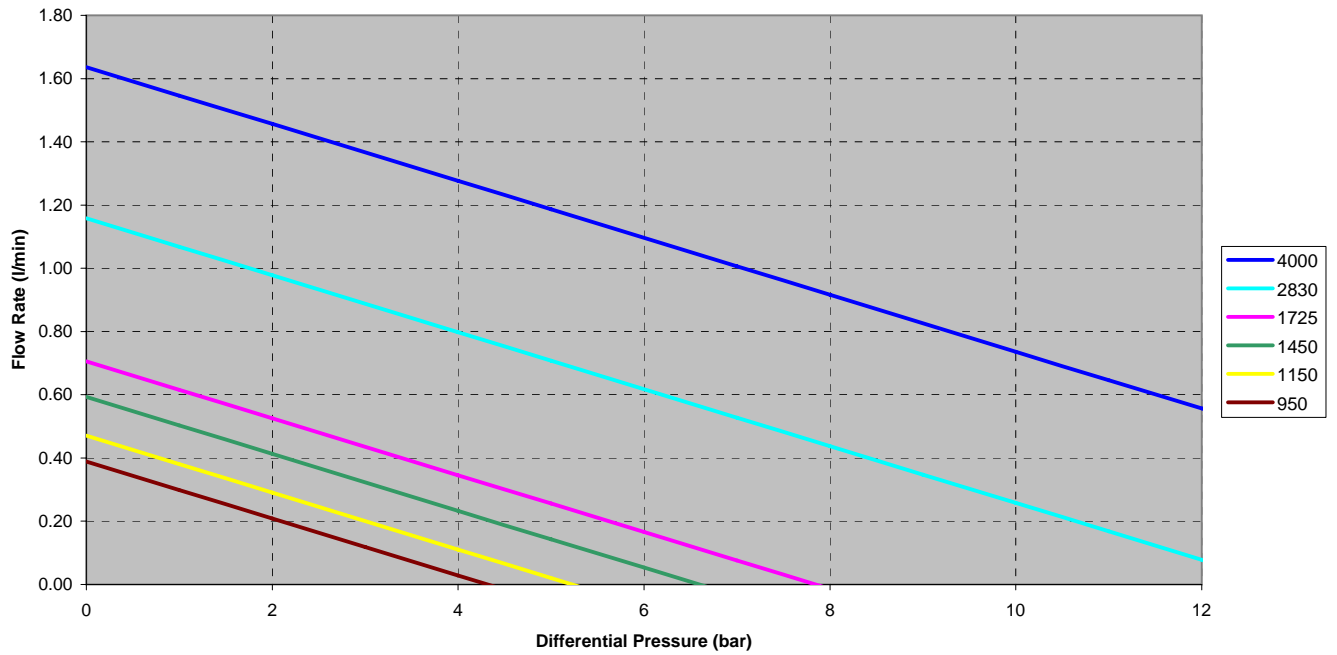

**Pump Head 3030-045
measured with oil 100mPas**

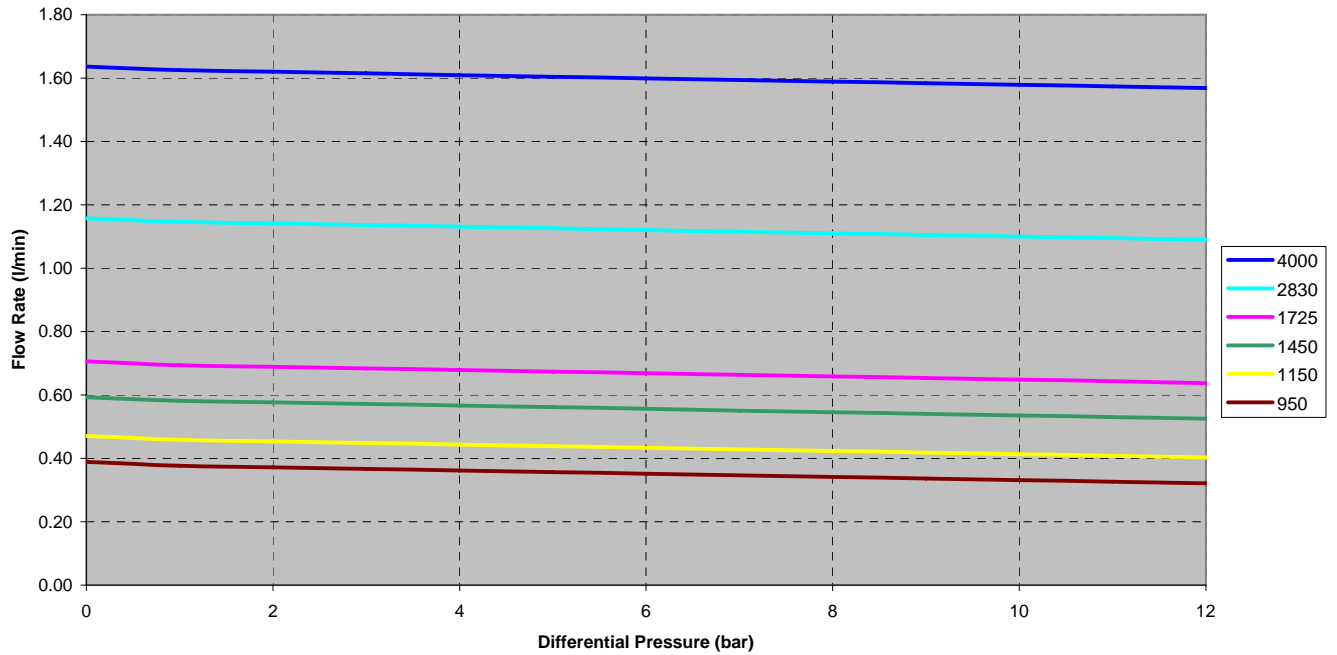

Magnetically Coupled Gear Pump Size 3030-070

**Pump Head 3030-070
measured with water 1mPas**

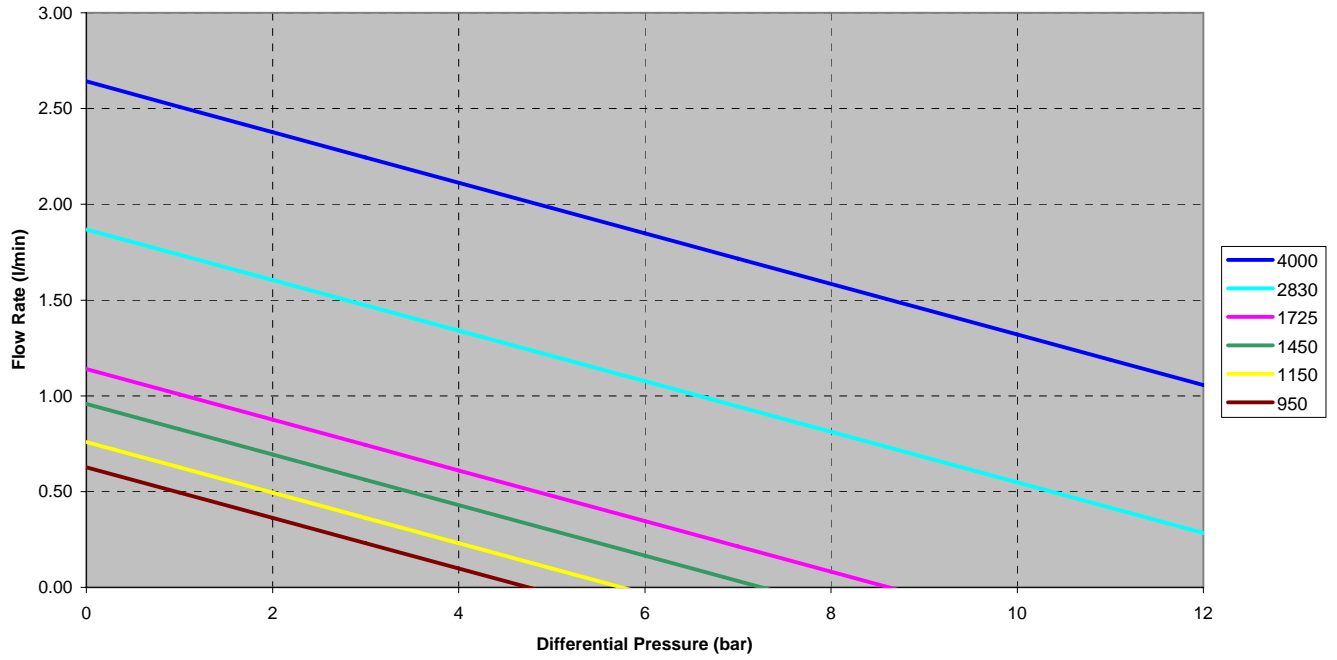

**Pump Head 3030-070
measured with oil 100mPas**

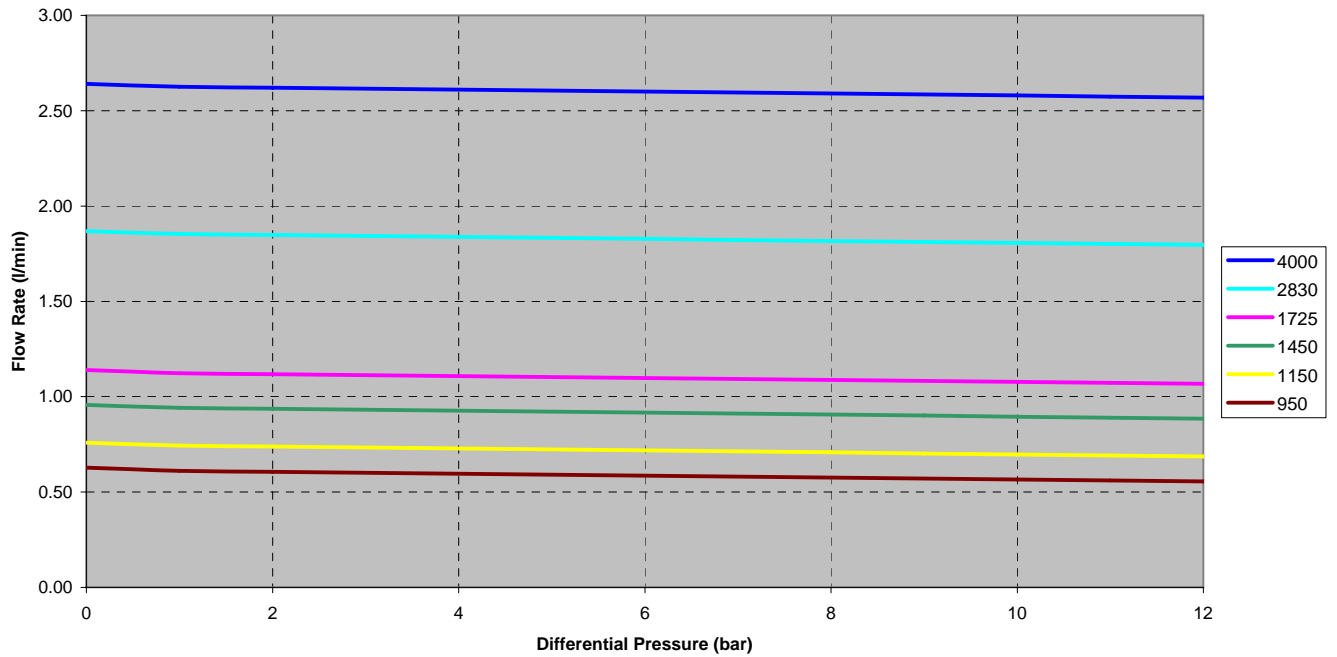

Magnetically Coupled Gear Pump Size 3030-110

**Pump Head 3030-110
measured with water 1mPas**

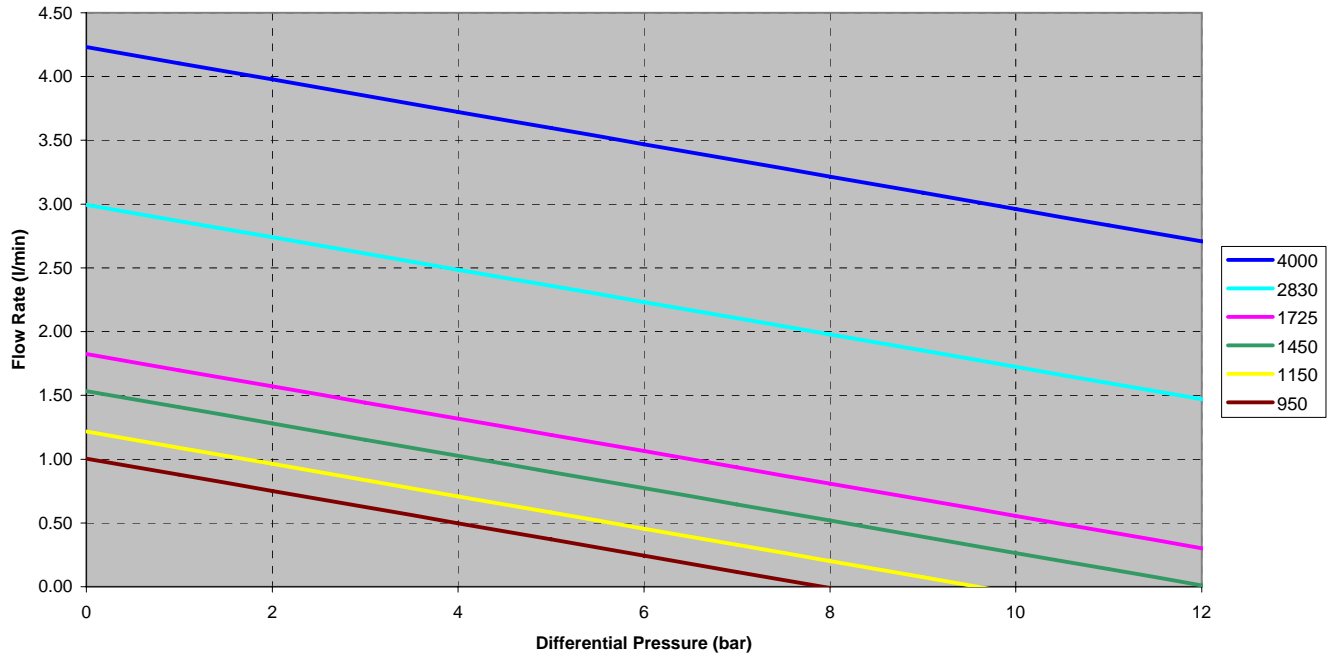

**Pump Head 3030-110
measured with oil 100mPas**

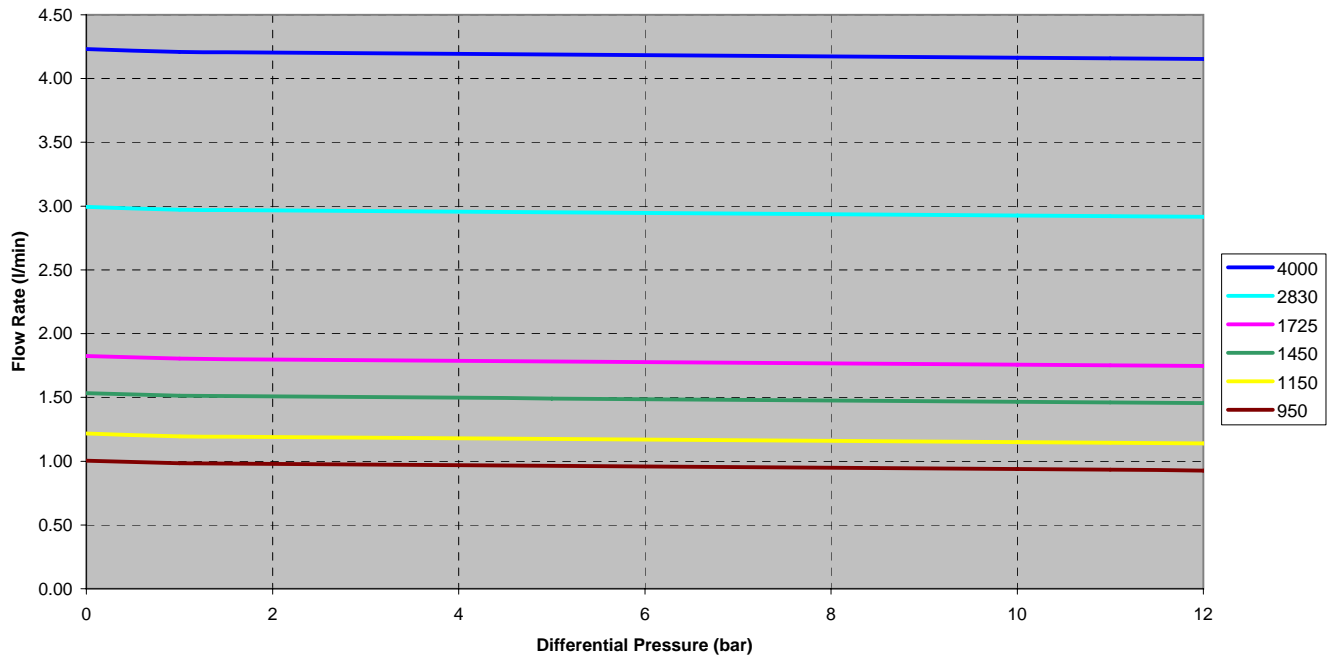

Magnetically Coupled Gear Pump Series 4030

Dimensions

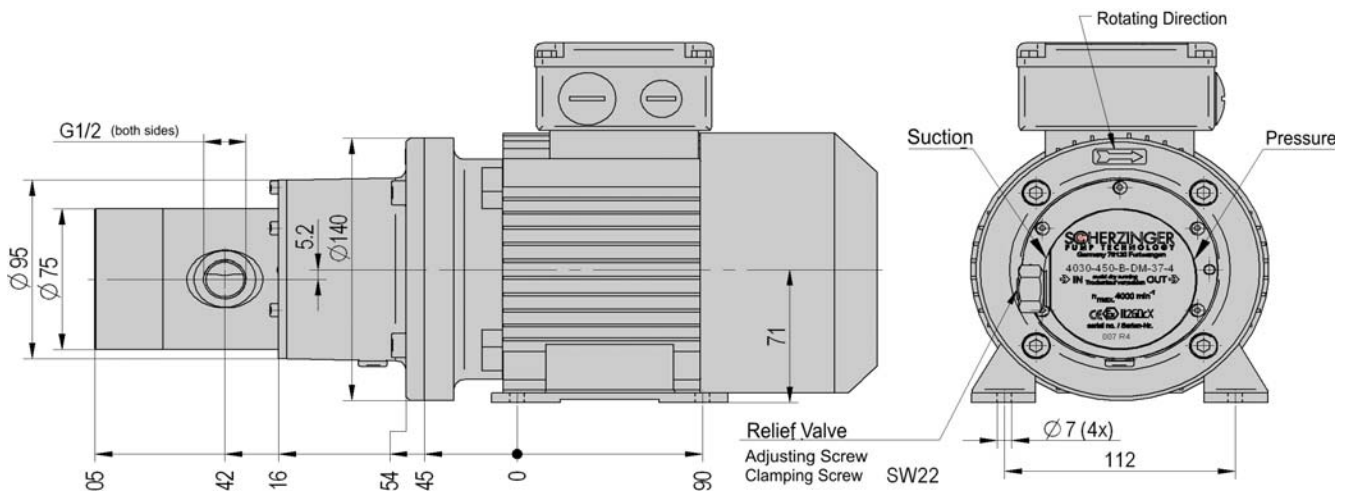

Typical dimensions of pump type 4030-450-B-DM37-4

Pump Specifications

	4030-280	4030-450	4030-710
Displacement	2.8 ml/rev	4.5 ml/rev	7.1 ml/rev
Max. Rotation Speed	3,500 RPM	3,500 RPM	3,500 RPM
Max. Discharge 1450 1/min	4.06 l/min	6.52 l/min	10.30 l/min
Max. Discharge 2830 1/min	7.92 l/min	12.73 l/min	20.05 l/min
Max. Discharge 3500 1/min	9.80 l/min	15.75 l/min	24.85 l/min
Max. Differential Pressure	14 bar	14 bar	14 bar
Max. Inlet Pressure	100 bar	100 bar	100 bar
Max. Suction Negative Pressure Absolute	80 mbar	80 mbar	80 mbar
Temperature Range PEEK	-20 to 130°C	-20 to 130°C	-20 to 130°C
Temperature Range PTFE	-20 to 70°C	-20 to 70°C	-20 to 70°C
Viscosity Range	0.5 to 3,000mPas	0.5 to 3,000mPas	0.5 to 3,000mPas
Direction of Rotation	optional	optional	optional
Connections	G 1/2"	G 1/2"	G 1/2"
By-Pass Relief Valve	optional	optional	optional
Max. Transmitted Torque of the Mag Drive	2 Nm	2 Nm	4 Nm

Material Standard Program 4030 and extended Standard Program 4040 & 4050

	Stainless Steel 4030	Hastelloy 4040	Titanium 4050
Case	1.4571	Hastelloy C4	Titanium Grade 7
Shafts	1.4571	Hastelloy C4	Titanium Grade 7
Gears	PEEK mod.	PTFE mod.	PTFE mod.
Magnets	SmCo	SmCo	SmCo

Customized designs and adaptations are possible after coordination with our engineering team.

Magnetically Coupled Gear Pump Size 4030-280

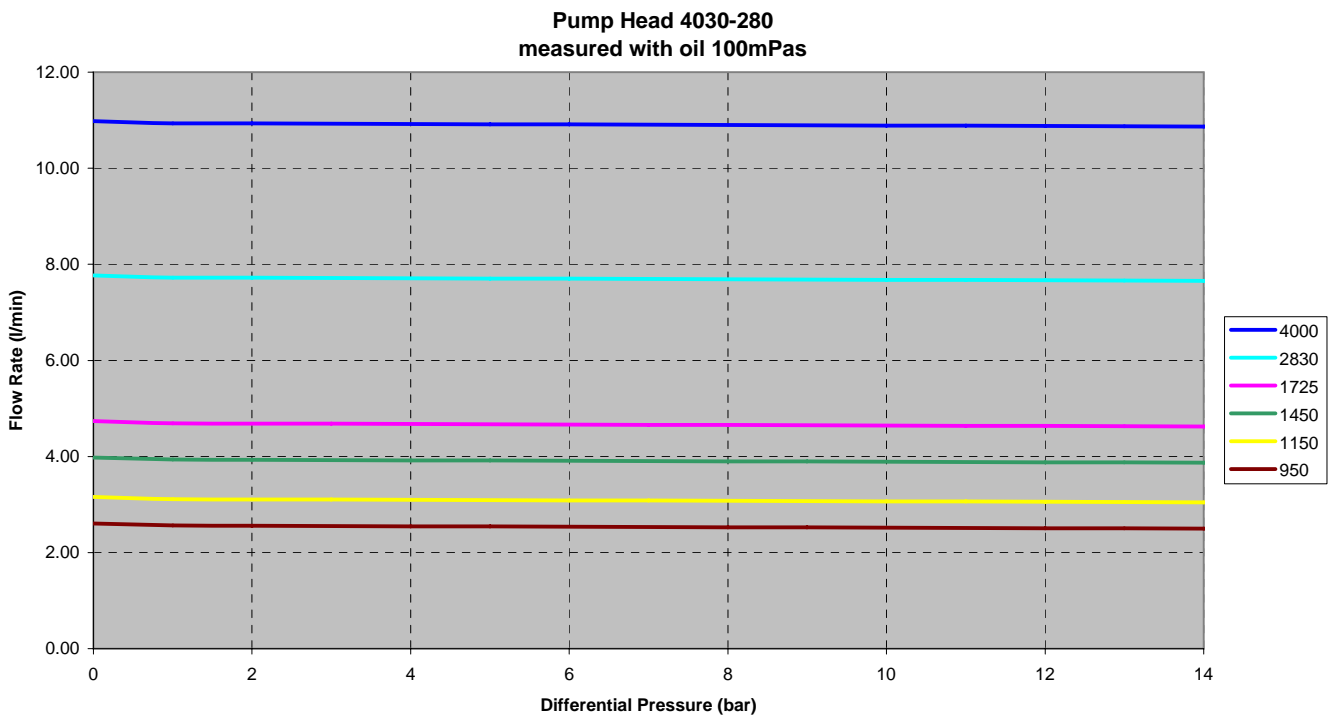
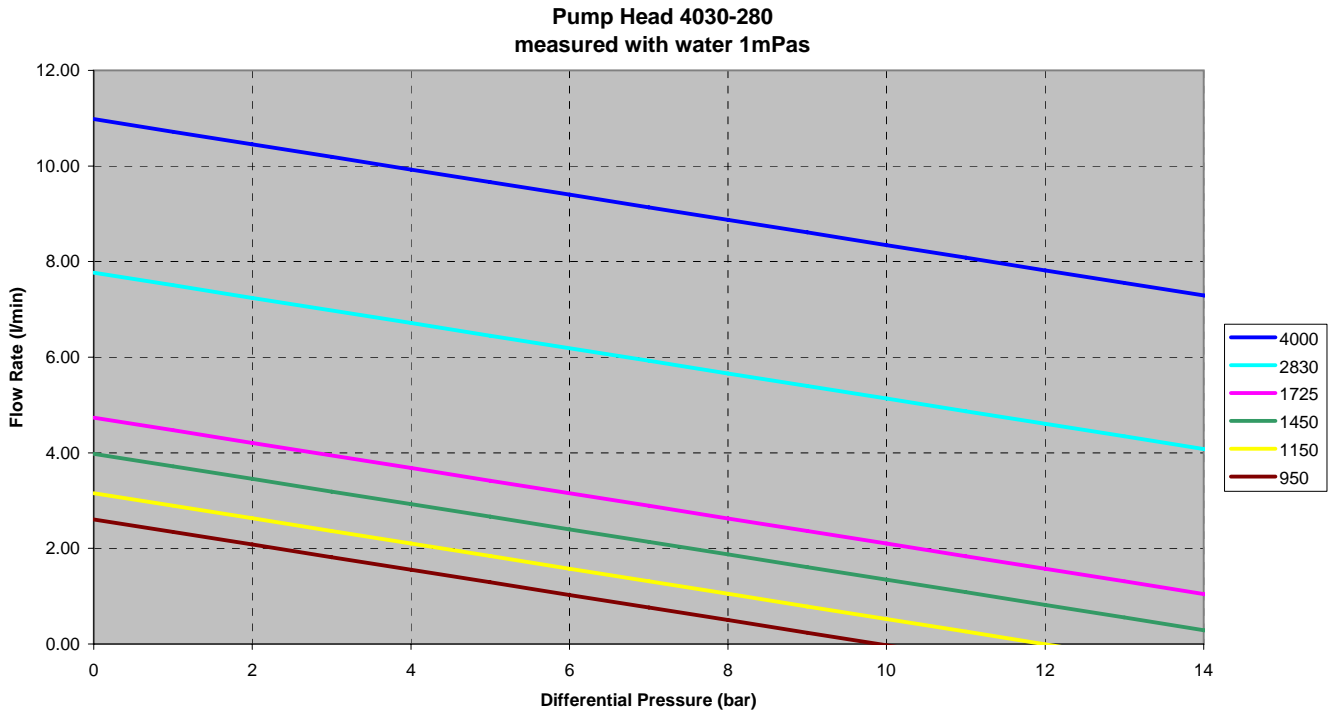

Magnetically Coupled Gear Pump Size 4030-450

**Pump Head 4030-450
measured with water 1mPas**

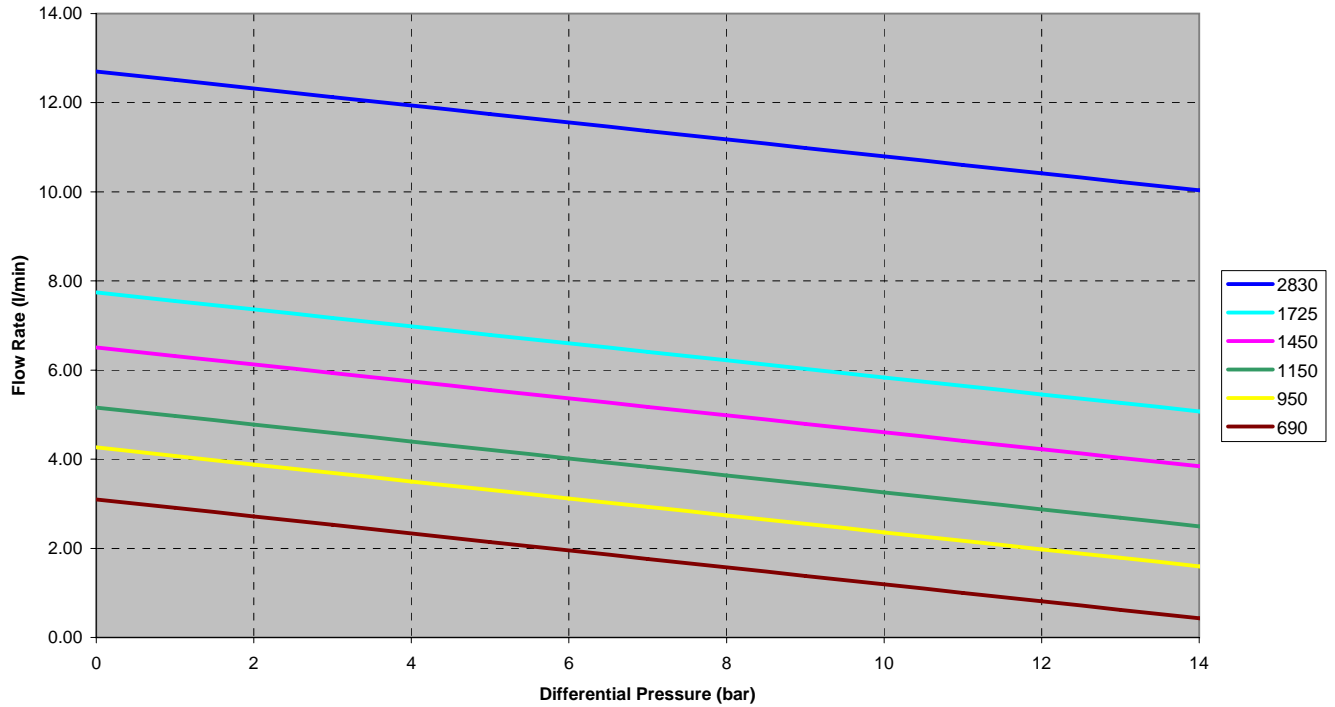

**Pump Head 4030-450
measured with oil 100mPas**

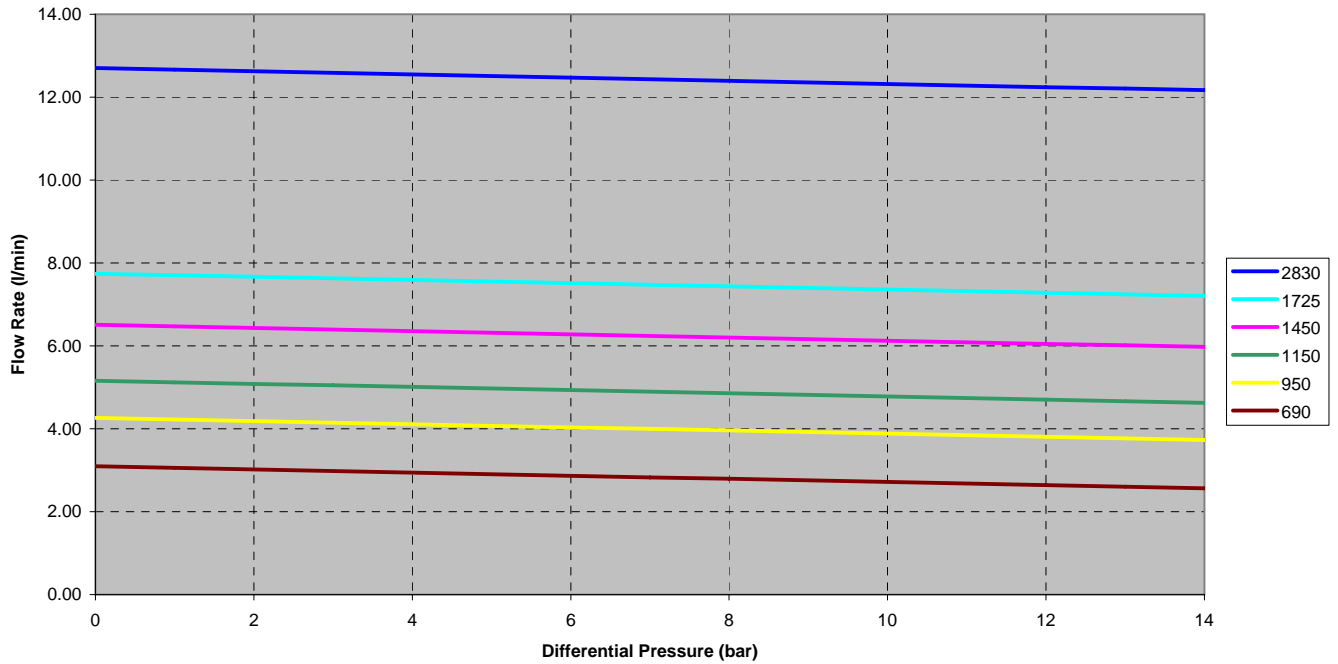

Magnetically Coupled Gear Pump Size 4030-710

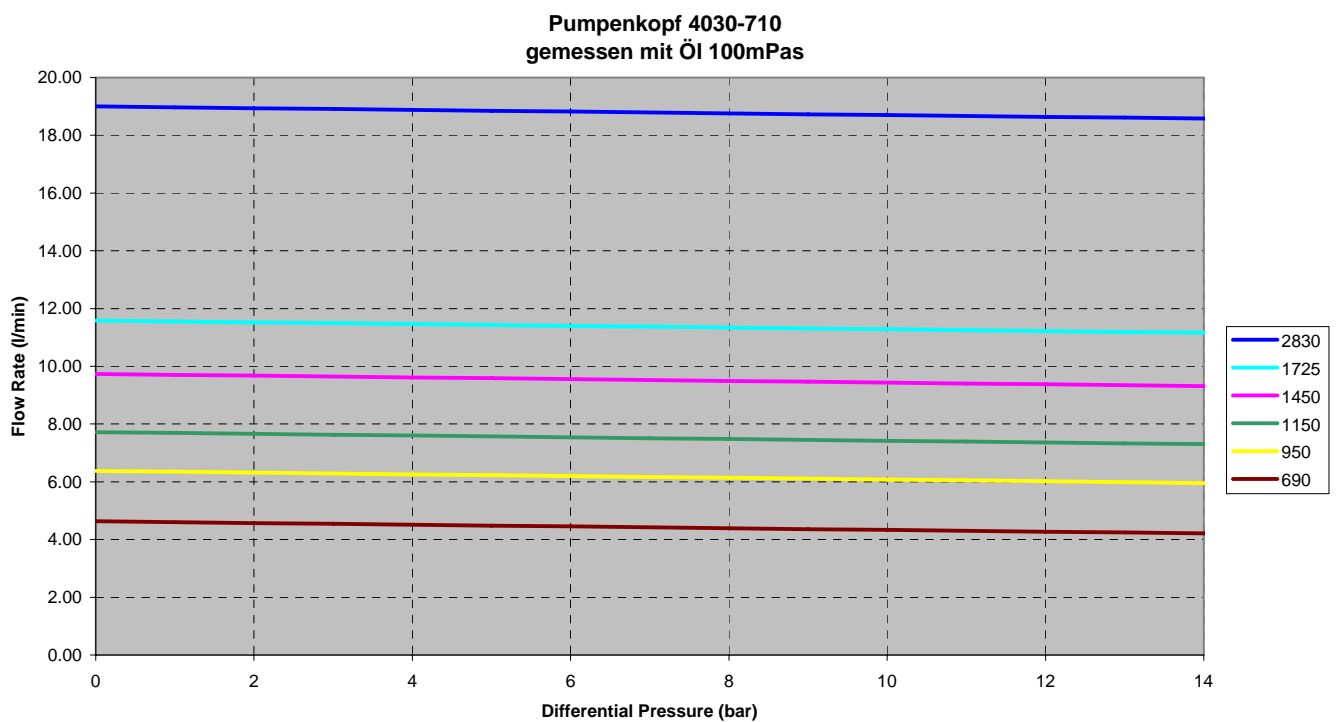
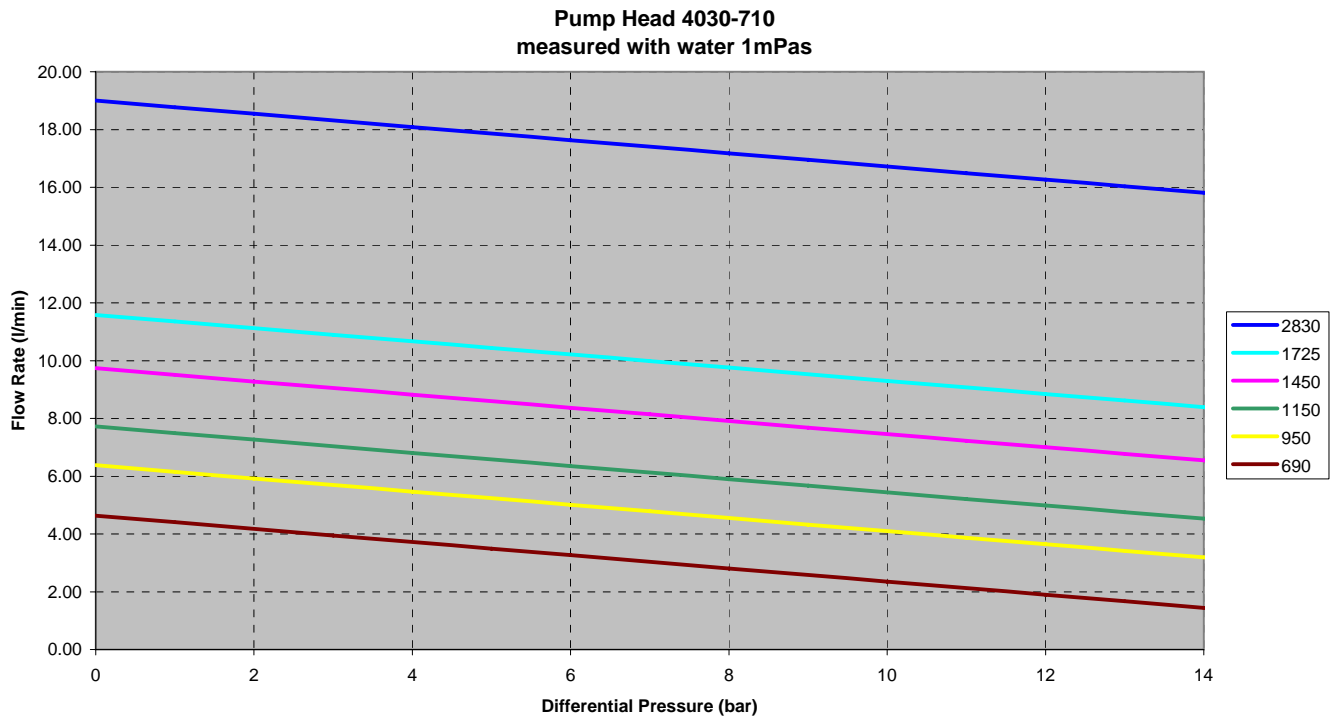

Magnetically Coupled Gear Pump Series 5030

Dimensions

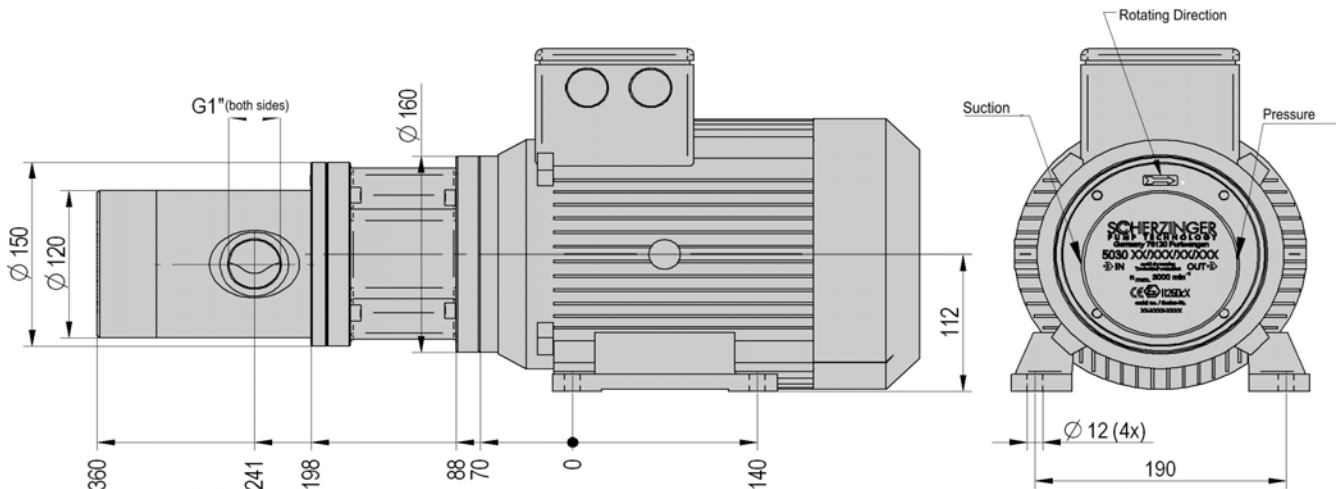

Typical dimensions of pump type 5030-350-DM300-6

Pump Specifications

	5030-130	5030-210	5030-350
Displacement	13 ml/rev	21 ml/rev	35 ml/rev
Max. Rotation Speed	3,000 RPM	2,500 RPM	2,500 RPM
Max. Discharge 1450 1/min	18.8 l/min	30.4 l/min	50.7 l/min
Max. Discharge 2830 1/min	36.7 l/min	59.4 l/min	---
Max. Discharge 3000 1/min	39.0 l/min	---	---
Max. Differential Pressure	16 bar	16 bar	16 bar
Max. Inlet Pressure	100 bar	100 bar	100 bar
Max. Suction Negative Pressure Absolute	80 mbar	80 mbar	80 mbar
Temperature Range PEEK	-20 to 130°C	-20 to 130°C	-20 to 130°C
Temperature Range PTFE	-20 to 70°C	-20 to 70°C	-20 to 70°C
Viscosity Range	0.5 to 3,000mPas	0.5 to 3,000mPas	0.5 to 3,000mPas
Direction of Rotation	optional	optional	optional
Connections	G 1"	G 1"	G 1"
By-Pass Relief Valve	Not Available	Not Available	Not Available
Max. Transmitted Torque of the Mag Drive	7.5 Nm	15 Nm	25 Nm

Material Standard Program 5030 and extended Standard Program 5040 & 5050

	Stainless Steel 5030	Hastelloy 5040	Titanium 5050
Case	1.4571	Hastelloy C4	Titanium Grade 7
Shafts	1.4571	Hastelloy C4	Titanium Grade 7
Gears	PEEK mod.	PTFE mod.	PTFE mod.
Magnets	SmCo	SmCo	SmCo

Customized designs and adaptations are possible after coordination with our engineering team.

Magnetically Coupled Gear Pump Size 5030-130

**Pump Head 5030-130
measured with water 1mPas**

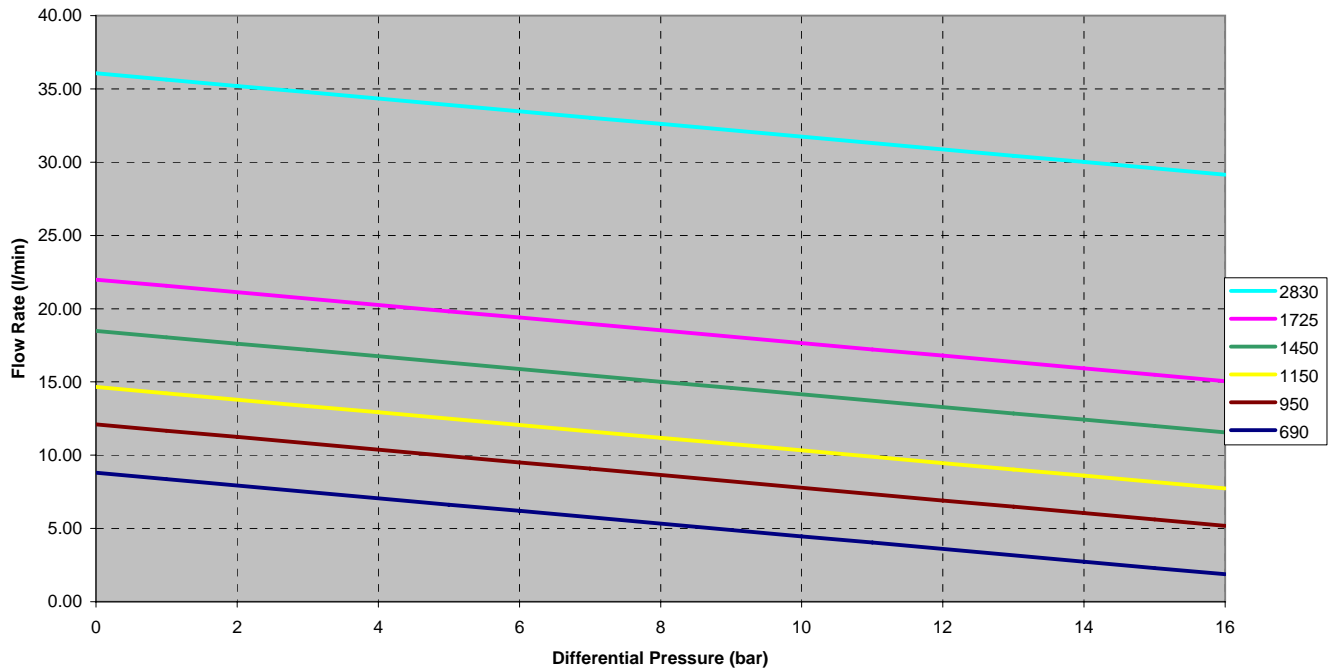

**Pump Head 5030-130
measured with oil 100mPas**

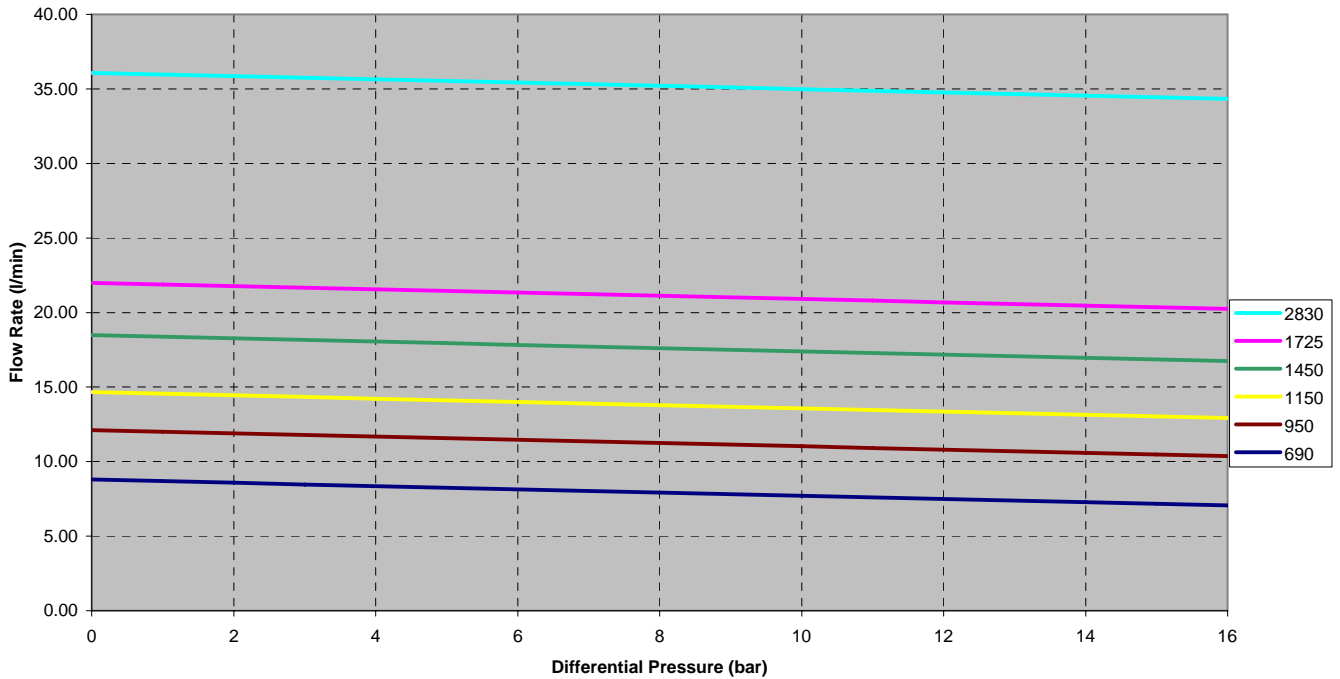

Magnetically Coupled Gear Pump Size 5030-210

**Pump Head 5030-210
measured with water 1mPas**

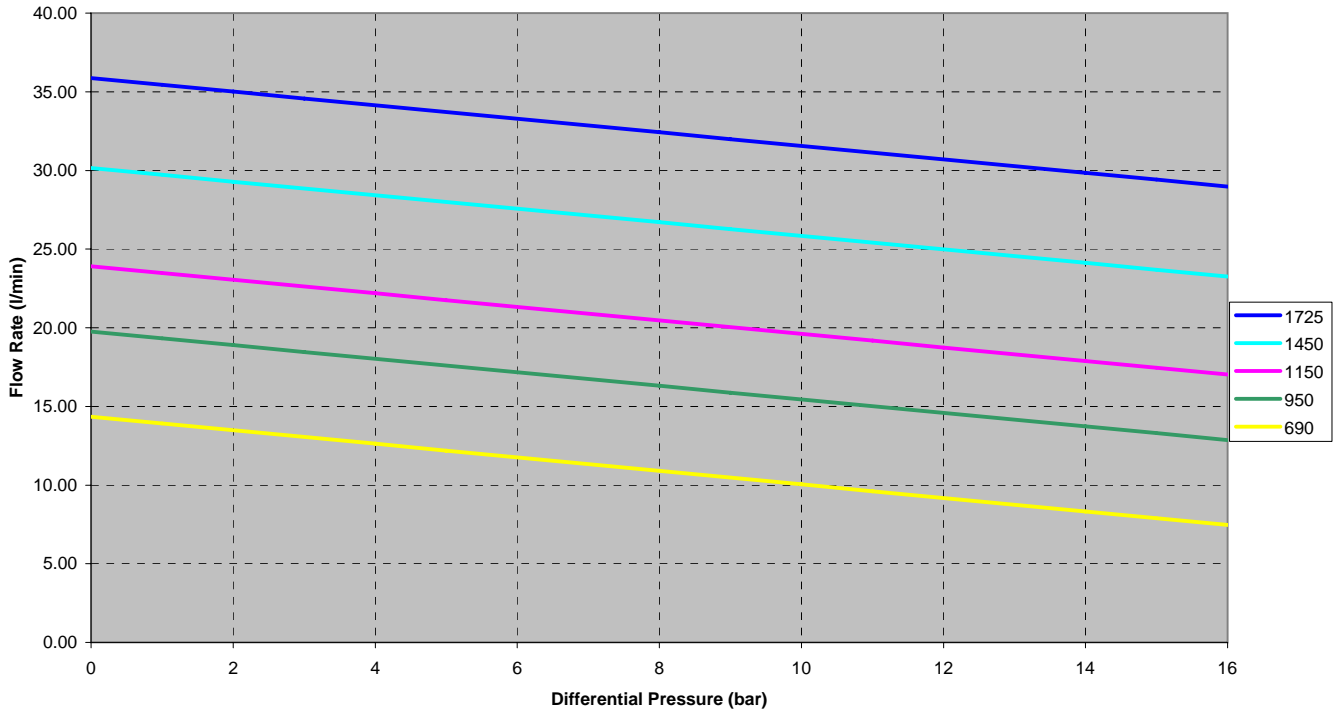

**Pump Head 5030-210
measured with oil 100mPas**

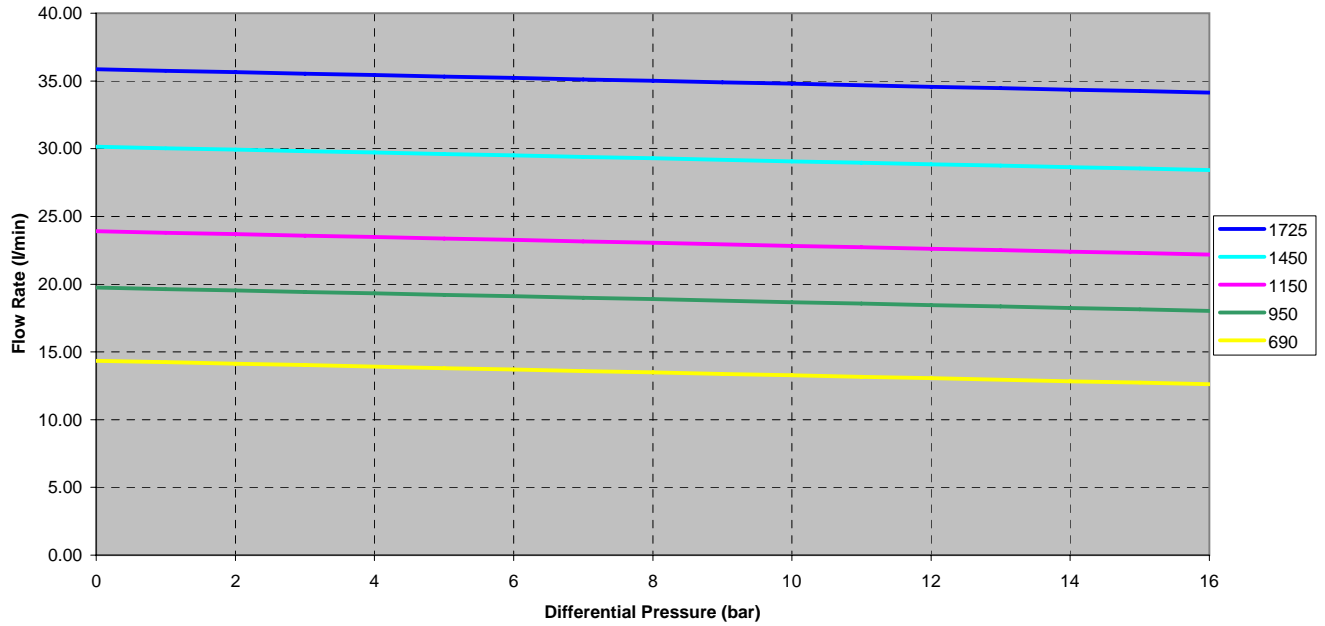

Magnetically Coupled Gear Pump Size 5030-350

**Pump Head 5030-350
measured with water 1mPas**

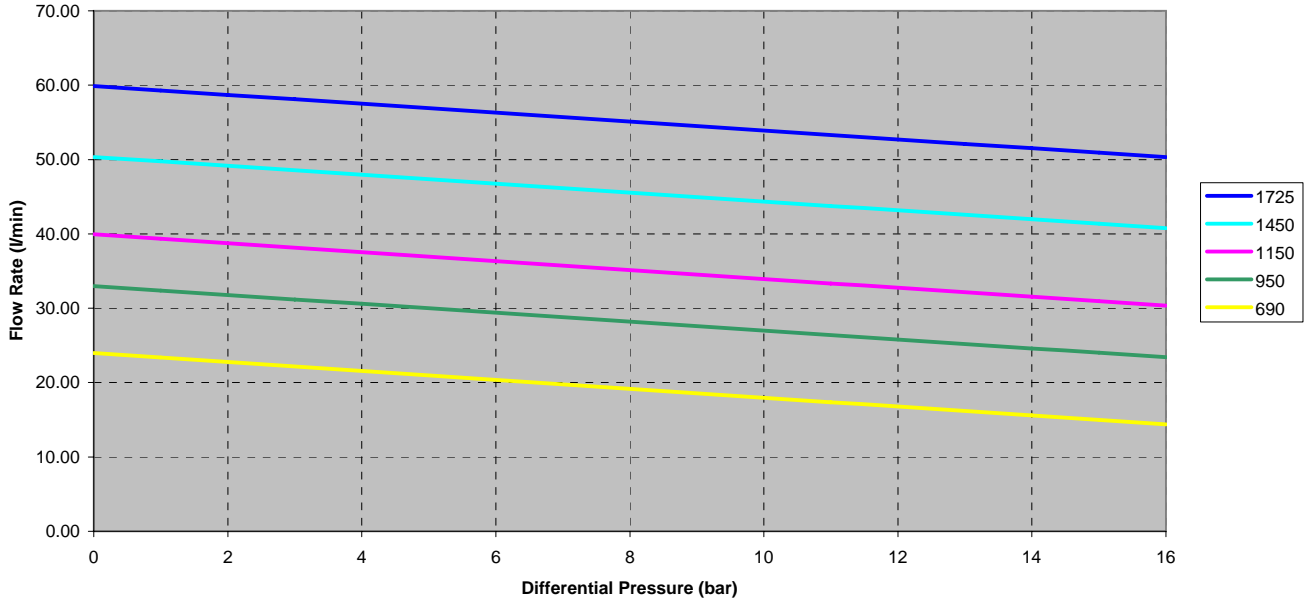

**Pump Head 5030-350
measured with oil 100mPas**

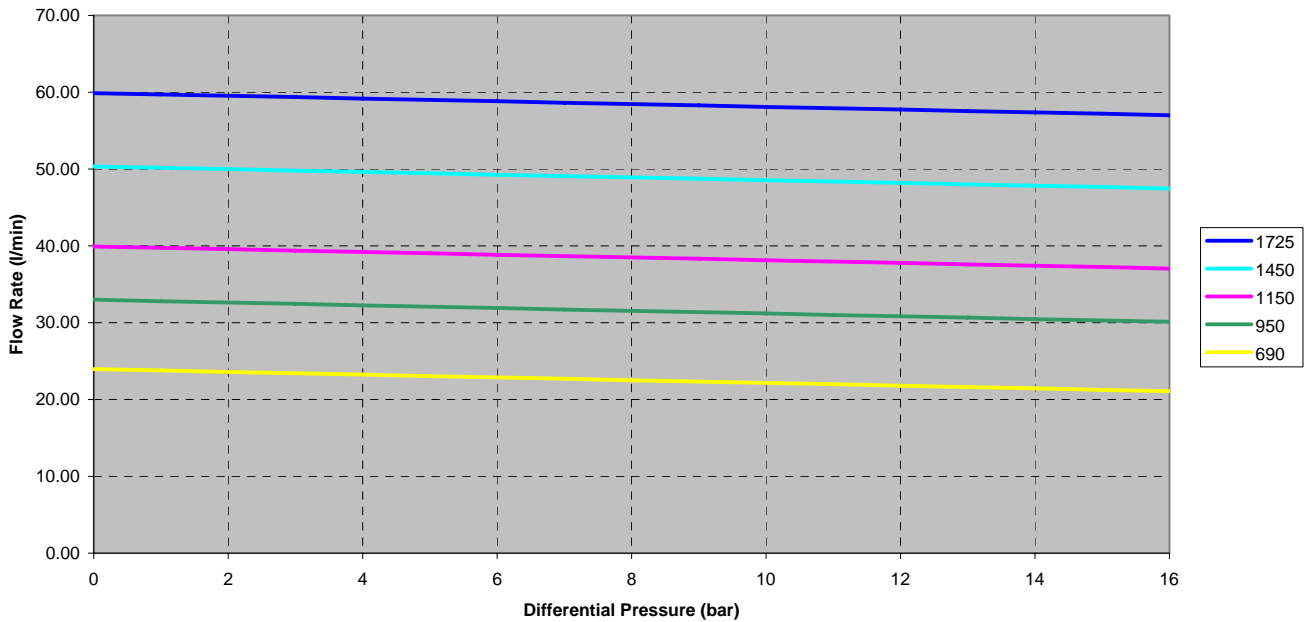



Automotive

Chemical

Energy

Medical

Transfer and Lube

Services

SCHERZINGER
PUMP TECHNOLOGY

**Pumpenfabrik
Ernst Scherzinger GmbH & Co. KG**
Bregstraße 23-25
D - 78120 Furtwangen
Telefon +49 (0) 7723 6506-0
Fax +49 (0) 7723 6506-40
info@scherzinger.de
www.scherzinger.de

Subject to changes 06.2010/GB